



SPLIT TYPE WALL MOUNTED AIRCONDITIONER

Sigma
White Edition

USER MANUAL

CHS09IN/DBW

CHS12IN/DBW

CHS18IN/DBW

CHS18IN/DBW

Caution: This product installation requires the expertise of a certified HVAC technician to maintain the warranty.

Please ensure thorough reading of the manual before operation and retain it for future reference. Note that this manual serves as a reference guide only. It is essential to adhere to the specifications of the actual appliances selected. Additionally, be aware that the manufacturer reserves the right to redesign or modify its products as needed.

Indoor Unit.



Outdoor Unit.



SAFETY PRECAUTIONS!

Warning: Adhering to these special installation precautions is paramount. Doing so significantly lowers the likelihood of encountering fire hazards, electrical shocks, injuries, or any potential loss of life arising from oversight or failure to adhere to installation instructions.



1. It's crucial to connect the air conditioner to a suitable electrical socket or breaker with the correct electrical supply, ensuring it only draws the specified amount of power, needed for it to function.
2. Proper grounding is essential to mitigate the risk of shock or fire. Avoid cutting or removing the grounding prong. If a three-prong electric receptacle outlet or breaker isn't available, enlist a certified electrician to install the necessary receptacle or breaker, ensuring proper grounding.
3. Refrain from using the unit if the power cord shows signs of fraying or other damage. Similarly, avoid its use if there are any cracks or abrasions along the length, plug, or connector.
4. Avoid using adapters or extension cords with the unit.
5. Prevent airflow blockage both inside and outside the air-conditioning unit. Ensure that blinds, drapes, protective covers, shrubs, or bushes don't obstruct airflow.
6. Exercise caution around the sharp edges of the unit's front and rear fins, which could cause serious injury if touched.
7. When lifting the air conditioner for installation or removal, take care and always seek assistance from two or more individuals.
8. Prioritize safety by disconnecting the power to the air-conditioning unit before servicing or removing it.
9. In certain types of units, there may not be suitable plugs corresponding to their power cords due to specific power requirements. In such cases, an appropriate power breaker should be connected to the unit's power cord. Consequently, the instruction section related to plug usage is not applicable for these types of units.

CONTENTS.

1. SAFETY INSTRUCTIONS

| | |
|-------------------------------|---|
| Symbol Description..... | 2 |
| Installation Instruction..... | 2 |
| Operating Instruction..... | 3 |
| Safety Instruction..... | 6 |

2. PRODUCT INTRODUCTION

| | |
|------------------------|---|
| Protect Functions..... | 7 |
|------------------------|---|

3. DESCRIPTION OF COMPONENTS

| | |
|---------------------------------|----|
| View of Unit..... | 8 |
| Display screen..... | 9 |
| Remote Controller | 10 |
| Remote Controller Display | 11 |

4. SERVICE AND MAINTENANCE

| | |
|---|----|
| Clean the Front Panel and Re mote Controller..... | 13 |
| Clean Air Filter..... | 13 |
| No Use for Long Time..... | 14 |
| Recommendations for Energy Saving..... | 15 |

5. TROUBLE SHOOTING

| | |
|------------------------------------|----|
| Air Conditioner is in Error..... | 16 |
| Remote Controller is in Error..... | 16 |

6. NORMAL PHE NOMENONS

17

SAFETY INSTRUCTIONS.

Symbol Description.

**Warning:**

A symbol indicating an operational error that may cause personnel casualties or serious damages.

**Caution:**

A symbol indicating an operational error that may cause personnel casualties or serious damages.

Installation Instruction.

**Warning.****Never Install Unit Yourself.**

A split-type air conditioner will maintain effective operation over extended periods if installed correctly. Improper installation may lead to functionality errors, including unit or refrigerant leakages, electric shock hazards, or even the risk of fire.

**Caution.****Please confirm the following before performing the installation of the unit:****1. Power Specifications:**

- Verify that the wall socket or breaker and power cable can handle the required capacity.
- Ensure correct voltage and grounded socket breaker to avoid fire hazards or electrical errors.

2. Proper Connection of Wires & Piping:

- Confirm proper connection to maintain efficiency and prevent A/C shutdown.
- Ensure no water or refrigerant leakage due to improper connection.

3. Installation Location:

- Avoid installing the air conditioner in combustible or chemically reactive areas to prevent corrosive air issues.

4. Operational Instructions:

- Operate the air conditioner according to the provided manual.

By confirming these aspects, you'll ensure a safe and effective installation process.

Operating Instruction.

WARNINGS

Please adhere to these installation precautions diligently to minimize the risk of fires, electric shocks, injuries, or loss of life. Your attention to detail ensures a secure environment for you and your loved ones. Thank you for your conscientiousness in following these instructions.

Electrical safety.

Grounding: This room air conditioner necessitates grounding for safety purposes.



Grounding serves to mitigate electric shocks by providing a pathway for electrical currents to dissipate. If the power cord is equipped with a grounding plug and wire, it should be plugged into a properly installed and grounded outlet. If the power cord lacks a grounding plug, ensure that the grounding wire connects to a correctly installed and grounded breaker.

Warning: Incorrect use of the grounding plug or breaker can increase the risk of electric shock. If you're uncertain about grounding instructions or the air conditioner's grounding status, it's advisable to seek guidance from a qualified electrician. If the wall outlet or breaker lacks grounding, it's essential to arrange for an electrician to replace it with a properly grounded one. This ensures optimal safety during the operation of the air conditioner.

Never cut or remove the third (ground) prong from the power cord under any circumstances!

We strongly advise against using an adapter plug or breaker.

Operating conditions.

1. Temperature:

- For **T1** instance: Operating within **-7°C to 43°C (-7°C to 43°C in cooling-only type)** is recommended.

- For **T3** instance: Operating within **-7°C to 52°C (-7°C to 52°C in cooling-only type)** is advised.

- Running the unit beyond these temperatures for prolonged periods might diminish cooling capacity or trigger the protector.

2. Relative Humidity:

- Maintain humidity levels below **80%** to prevent condensation near the blade and air outlet, This occurrence is normal.

- In heating operation, a peculiar smell may arise from the unit, which is also considered normal.

- Performance parameters are outlined on the nameplate.

- The indoor unit's waterproof level is **IPX0**. Avoid using it in areas prone to moisture, such as laundry or bathroom areas.

- Ensure the outdoor unit is not installed in a closed area to facilitate proper ventilation.

These precautions! aim to optimize the performance and longevity of the air conditioning unit while ensuring user safety and comfort.

Tips: For optimal operation, consider the following guidelines:

- Install the unit on the north side, away from sunlight, for optimal performance.
- Ensure correct electric voltage and appropriate amperage to facilitate efficient functioning.
- Modifications to electrical outlets or breakers must only be performed by certified electricians.
- Utilize a dedicated line to prevent electrical surges and ensure consistent power supply.

If the supply cord sustains damage, it must be replaced by the manufacturer, its service agent, or a similarly qualified individual to mitigate potential hazards. Adhere to national wiring regulations for proper installation, including maintaining minimum distances from adjacent structures. Always disconnect the power supply before undertaking cleaning or maintenance tasks.

If the appliance isn't connected by plug, incorporate an all-pole disconnection device with at least **3mm** separation distance in all poles, and a residual current device (**RCD**) with a rating above **10mA** into the fixed wiring, as per national rules. If connected by plug, position it for easy accessibility. These precautions ensure safe and efficient operation of the appliance.

Energy Saving Guide

During the air conditioner installation process, it's essential to seal any potential air leakage points thoroughly. This ensures efficient operation and prevents energy wastage. Additionally, ensure that there is unrestricted airflow both inside and outside the unit, avoiding blockages from curtains, drapes, or furniture. Keep shrubs or bushes clear from the outdoor unit to maintain proper ventilation.

To optimize cooling efficiency, minimize the use of heat-producing appliances such as electrical lights. Keeping blinds and drapes drawn on all other windows helps to reduce solar heat gain. Furthermore, when cooking, utilize a kitchen exhaust fan to eliminate excess heat, further enhancing the effectiveness of the air conditioning system.

By implementing these measures, you can maximize the performance of your air conditioner while minimizing energy consumption and maintaining a comfortable indoor environment.

Operating Instructions.

Use only single-phase AC power.
Refer to the nameplate for specific details.

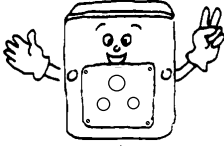

Use the specified power cord provided
and do not replace it with another.

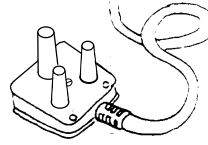

Avoid inserting fingers or objects
into the air conditioner's inlet or outlet as the
running fan may cause injuries.

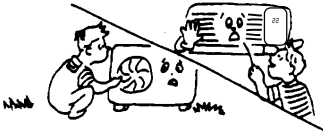

Avoid placing anything
on the outdoor unit.

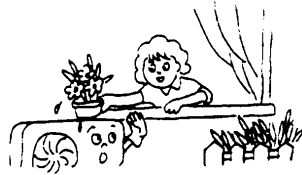

Do not switch the unit on or off by plugging or
unplugging the plug, or by toggling the breaker.
Use the designated controls for operation.



Keep the indoor area ventilated, especially
when operating gas equipment.



Do not replace the fuse with
lead wire or any other materials.



If the air conditioner is not used for an
extended period, unplug the power plug
or switch off the breaker.

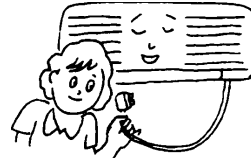

Safety Instructions.

Warning: The appliance is not designed for use by young children or individuals with disabilities without supervision. It's crucial to supervise young children to prevent them from playing with the appliance, minimizing the risk of accidents or injuries. In the event of damage to the supply cord, it must be replaced by the manufacturer, its service agent, or a similarly qualified individual to mitigate any potential hazards. This ensures the continued safe operation of the appliance.



Never connect the earth line to a gas pipe or water pipe. Improper grounding can lead to electric shock.

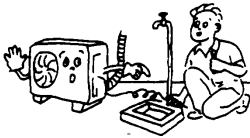

Do not pull out the power plug or switch off the breaker while the appliance is in operation.

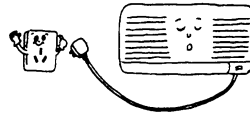

Switch off the unit, disconnect the power source, and contact a service agent if any abnormal phenomena occur (e.g., a burning smell).



Do not install the air conditioner in areas where flammable gas may leak.

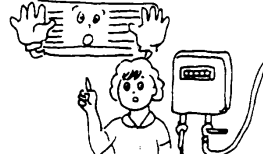

Do not place plants or animals directly in the path of the air conditioner's airflow, as it could harm them.



Please contact service agents for any required maintenance or repairs. Improper service may lead to complications.



Before cleaning the unit, switch it off, disconnect the power source, and ensure the fan has stopped.

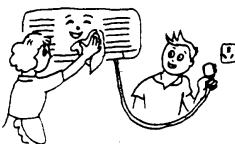

For removal of Unit please contact a professional to help carry out maintenance.

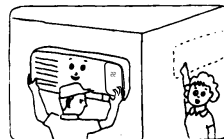

PRODUCT INTRODUCTION

Protect Functions.

These protective functions contribute to the efficient and safe operation of the air conditioner while ensuring user comfort and convenience.

1.Delay-starting protection for the compressor:

The compressor restarts operation after being turned off, maintaining pressure balance in the cooling system. It waits at least **3 minutes (5 minutes in heating mode)** to resume operation.

Remarks:

Upon initial electrification, there will be a **1-minute** compressor operation.

2.Defrosting (not available for cooling-only type air conditioner):

In low outdoor temperature and high humidity conditions, auto-defrosting operates for **3-10 minutes** to remove frost from the outdoor heat exchanger.

3.Heating overload protection (not available for cooling-only type air conditioner):

When indoor pipe temperature is too high, the air conditioner enters heating overload protection. The indoor fan speed adjusts automatically. Outdoor fan and compressor may stop until the indoor pipe temperature drops to a rated value.

4.Blowing residual heat function (not available for cooling-only type air conditioner):

In heating mode, the indoor fan runs at low speed for **80 seconds** after the air conditioner is stopped.

5.Cooling airflow proof (not available for cooling-only type air conditioner):

Initially, for about **7 minutes** the indoor fan does not run, and louver blades cannot be controlled during heating operation. After about **5 minutes**, the air conditioner starts blowing heat airflow.

6 Freeze-prevention:

To prevent indoor heat exchanger freezing, the compressor or outdoor fan may stop running, and the indoor fan speed adjusts automatically.

7.Dry for enzyme-prevention (optional):

In cooling mode, the indoor fan motor runs for **3 minutes** at low speed after turning off to maintain a dry condition inside the unit.

8.Reset power or Auto restart (alternative):

Reset power: After a power suspension, the air conditioner switches off automatically. Upon power restoration, the unit resets automatically. If no one is in the room, it stays in **PAUSE** status until manually turned on.

9.Auto restart:

The unit remembers its operation mode, airflow setting, and temperature setting. In case of a power failure during operation, it returns to the same conditions upon power restoration.

10.Cooling overload working (optional):

Cooling overload protection feature.

During cooling operation, if the temperature of the outdoor heat exchanger rises excessively, the indoor fan speed will automatically adjust to a lower setting, and the compressor may stop to prevent overheating.

Additionally, for added functionality, a drip-proof feature **(optional)** is available. In cooling and dehumidification modes, the louver blades can automatically change position to prevent dripping, enhancing the overall performance and efficiency of the air conditioning unit.

DESCRIPTION OF COMPONENTS.

View of Unit.

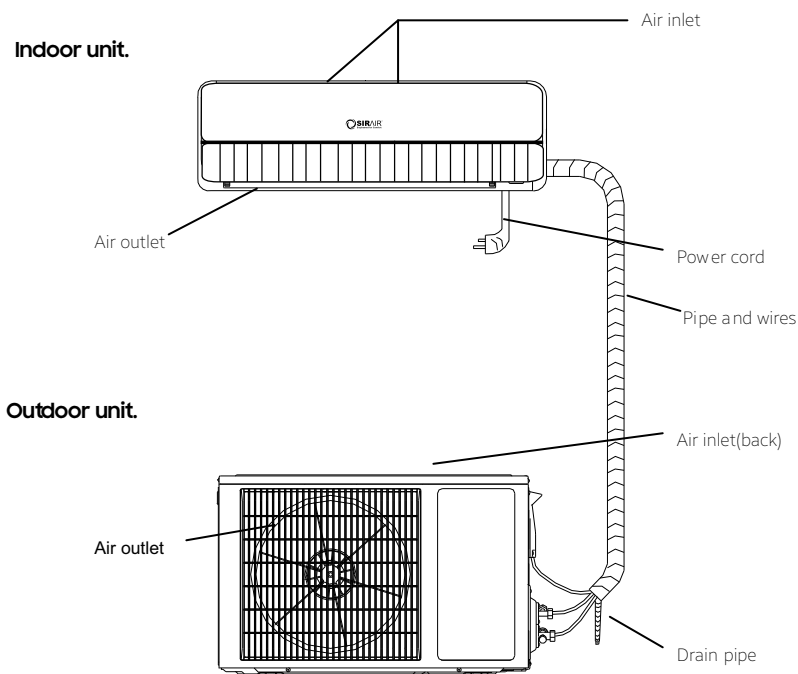

Remarks:

The air conditioner comprises an indoor unit, outdoor unit, and remote controller. Please note that the design and shape of these components may vary across different models. The figures provided above are schematic representations and may slightly differ from the actual appliances you have selected.

Display Screen.



Health indicator: The health indicator light illuminates when either the **UVC**, function or the Cold Plasma Generator is operational.



Timer indicator: The signal indicator light illuminates when the unit is in timer mode.



Compressor indicator: The signal indicator light is illuminated when the, compressor is running.



WiFi indicator: Flashing indicates searching, while lighting up signifies that the **WiFi** connection has been successfully completed. This indicates that the **WiFi** function is ready for operation and application. For further details, please consult the **WiFi** instruction manual.



Temperature indicator: The signal indicator light displays the set temperature, If the indicator displays **F1**, **F2**, or **F4**, it indicates that the air conditioner is running abnormally and requires checking.

(The above LED display is for reference only, subject to the actual product)

Remote Controller.

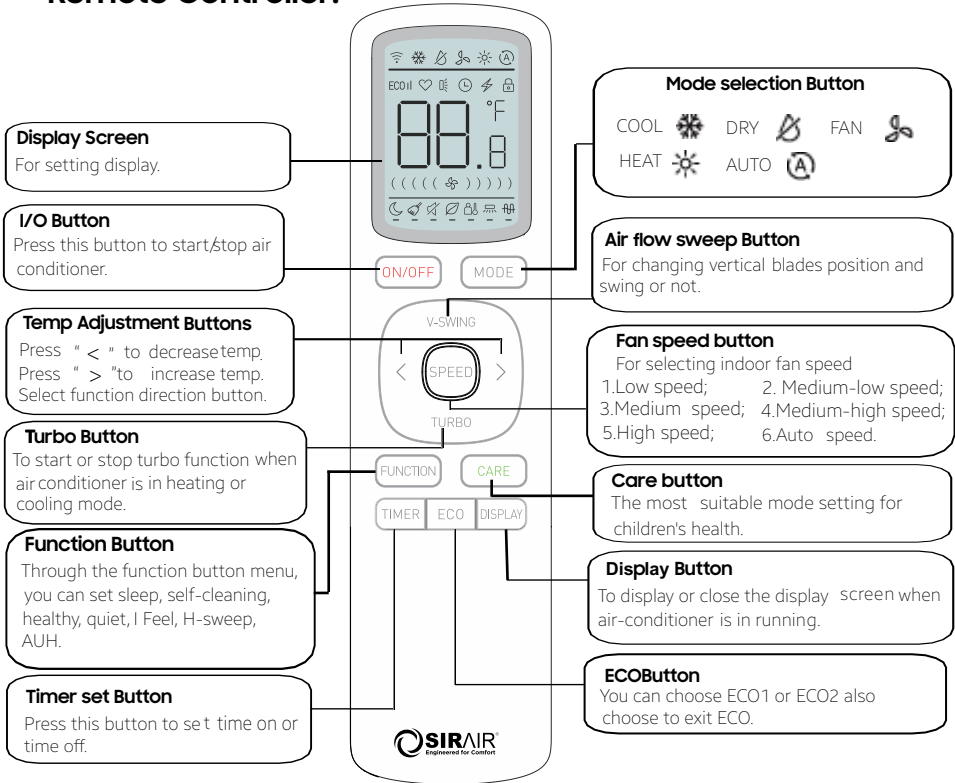

Remarks:

1. To rapidly cool or warm the room, press the **"turbo"** button in cooling or heating mode, activating the air conditioner's power function. Press the **"turbo"** button again to exit the power function.
2. The illustration of the remote controller provided is for reference only and may slightly differ from the actual product you have selected.
3. To select a function, access the function menu and use the add-subtract button to navigate and select the corresponding function. The selected function item will flash. Press the function button to move to the next function position of the last set function. You can adjust the position of the function to be set using the add and subtract keys. The function to be set will flash for **10 seconds**. Press the function key within **10 seconds** to select this function. The lower horizontal line of the selected function icon will light up. Press the function button again to cancel the function, and the lower horizontal line will deactivate.
4. Press and hold the **"Temperature Up"** and **"Temperature Down"** keys for **5 seconds** after turning on the machine to switch the display to Fahrenheit. Press and hold the **"Temperature Up"** and **"Temperature Down"** keys for 5 seconds again to switch back to Celsius.

Additional Remote Controller.

The new sirair remote controller is equipped with a **UVC Button**, providing convenient access to the air sterilization function.

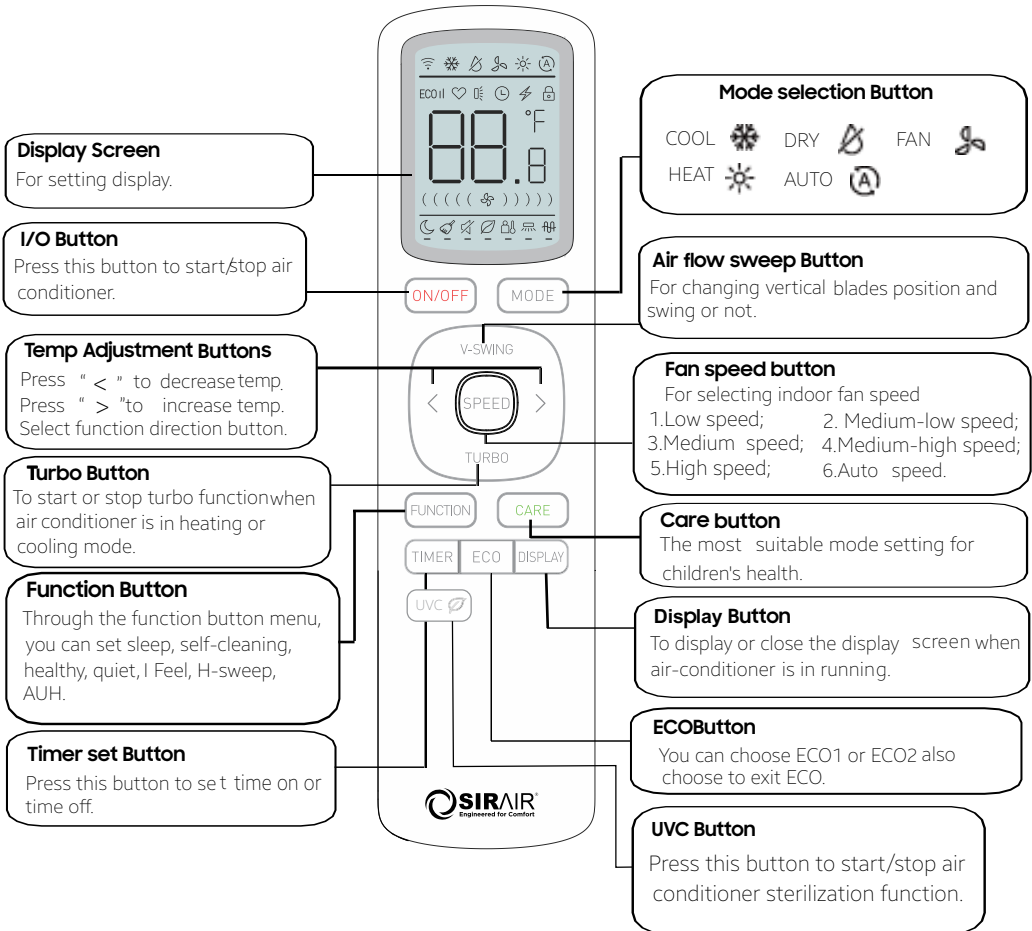

This remote controller is exclusively designed for use with **UVC** functional products manufactured by Sirair.

In case the remote controller is missing or the batteries are depleted, you can utilize the Emergency Button.

Operation Method:

1. With the air conditioner in the **"OFF"** state, open the front board.
2. Using the tip end of a ballpoint pen or a similar object, press the Emergency Button.
3. The air conditioner will then operate in **"AUTO"** mode.
4. To turn off the unit, press the Emergency Button again.

To adjust the horizontal airflow direction manually:

If the **"H-SWEEP"** button on the remote controller doesn't activate the horizontal louvre blades to swing, follow these steps for manual adjustment:

- Refer to Figure 1 for manual adjustment instructions.

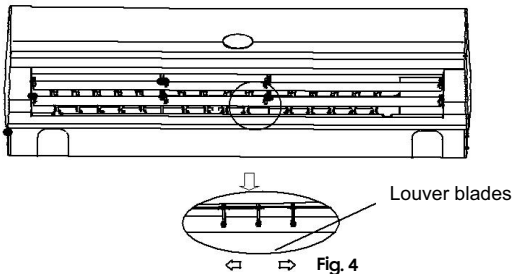

Warning:

Fan inside;
Keep hands away!

Sleep Operation.

1. When the air conditioner is running, press the **"SLEEP"** button on the remote controller to activate **"SLEEP"** mode. The corresponding indicator will display on the remote controller.
2. Press the **"SLEEP"** button again to cancel the sleep (**energy-saving**) function, and the indicator will disappear from the remote controller.

Note:

1. Function **a**: In sleep mode, the set temperature will be adjusted after 1 hour of operation in cool and **DRY** mode (increased) or heating mode (decreased). The set temperature will be maintained between **16°C and 32°C**. While the air conditioner is in sleep mode, the indoor fan speed is set to a medium level by default, but users can adjust the fan speed using the remote controller.
2. Function **b**: In sleep mode, the set temperature and indoor fan speed remain unchanged, but the display screen of the air conditioner will turn off, except for the "RUN" indicator.
3. Function **a** or function **b** is optional and is pre-set before the product is dispatched from the factory.

SERVICE AND MAINTENANCE.

Careful maintenance and regular servicing can prolong the service life of the air conditioner and reduce electricity costs.

Caution:

1. Always stop the air conditioner using the remote controller and unplug it before performing any service or maintenance.
2. Avoid standing on unstable objects when cleaning or servicing the air conditioner to prevent personal injury.
3. When removing the front panel, avoid touching the metal parts of the body to prevent personal injury.

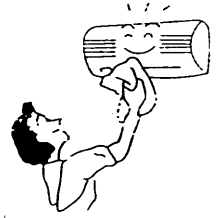

To Clean the Front Panel and Remote Controller:

If dust cannot be easily removed, use a warm damp cloth soaked with water below **40°C**.

Caution:

1. Avoid cleaning the unit with water to prevent electric shock.
2. Do not clean the remote controller with water.
3. Avoid using alcohol, gasoline, banana oil, or polishing agents for cleaning.
4. Avoid cleaning the unit forcefully to prevent the front panel from falling down.
5. Do not use a metal brush to clean the front panel or remote controller, as it may damage the surface.

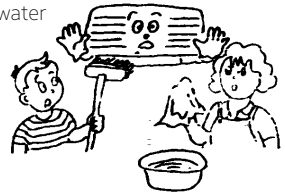

Clean Air Filter.

1. Open the front panel. **(Refer to Fig. 4)**
2. Lift the protruding part, then pull it downward to remove the air filter.
3. Clean the air filter using a vacuum cleaner or water. If the air filter is very dirty, clean it with warm soapy water or mild detergent. Then, dry it in the shade.
4. Reinsert the air filter into its previous position, and close the front panel.

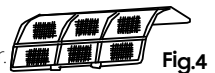

Note:

1. The air filter should be cleaned at least once every two weeks to prevent a reduction in heating or cooling capacity.
 2. Avoid cleaning the air filter with a metal brush, as it may cause damage.
-

No Use for Long Time?

1. Allow to swing, **3-4 hours** for the internal components to dry.

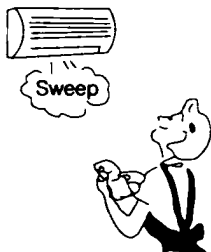

2. Stop the operation using the remote controller, then turn off the air conditioner and disconnect its power source.

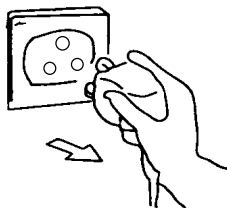

3. Clean and maintain the air filter net.

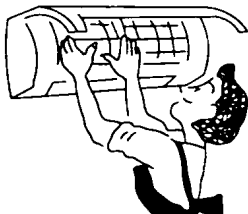

4. Remove the batteries from the remote controller.

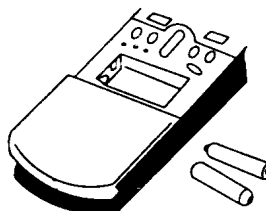

Recommendations for Energy Saving.

Appropriate Temp Setting.

Exposing oneself to overly cold temperatures can be detrimental to health.

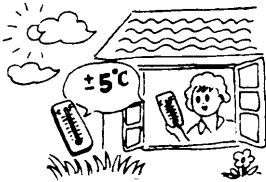

Avoid Direct Sunlight.

When using the air conditioner for cooling, please use curtains or blinds to block direct sunlight.

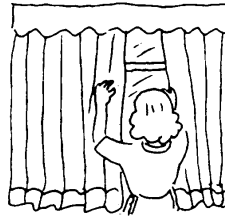

Avoid Heat Sources.

When the air conditioner is cooling, using other heat sources may affect its cooling effectiveness.



Close Doors and Windows.

Incoming outdoor air can affect the cooling or heating efficiency of the air-conditioning unit. Therefore, ensure that you keep all windows and doors closed when using the air-conditioner.

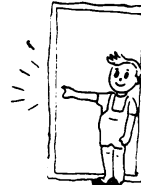

Keep Air Filter Clean.

Keeping the air filter clean ensures high operational efficiency.

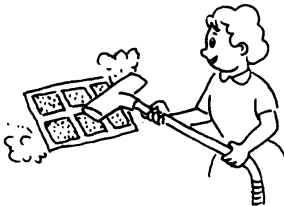

Good Ventilation.

Do not place objects in front of the inlet and outlet of the outdoor unit.

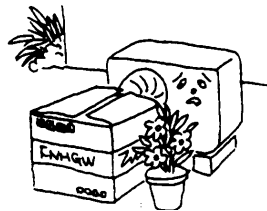

TROUBLESHOOTING

Air Conditioner is in Error

Here's a checklist you can follow before calling for service or repairs:

| Phenomenon. | Checking The Following: |
|--|--|
| Air-conditioner does not operate at all. | 1. Check whether the power is disconnected. |
| | 2. Check whether the breaker is switched on or the fuse is burnt. |
| | 3. Check the remote controller, batteries. |
| | 4. Check whether radio equipment is used within 1m around the unit. |
| Poor cooling or Heating Performance. | 1. Check whether the air inlet or outlet is blocked. |
| | 2. Check whether dust is blocking the filter. |
| | 3. Check If there are too many people indoors, it affects performance. |
| | 4. Check whether doors or windows are closed. |
| | 5. Check whether fan speed or set temperature is improper. |

If your remote controller is displaying an error message or indicating an error condition, here are some steps you can take to troubleshoot the issue:

Here's a list of troubleshooting scenarios that are considered normal phenomenon:

| Phenomenon. | Checking The Following: |
|---|--|
| If the fan stops or the fan speed cannot be adjusted or controlled, please check the following: | 1. In DRY mode or SLEEP mode, there may be instances where the fan speed cannot be controlled. |
| | 2. When the air conditioner is in COOL AIRFLOW PROOF or DEFROSTING operation (in HEAT mode), the fan motor will stop. |
| | 3. When the air conditioner is in COOL or DRY mode and enters freeze-prevention operation, the fan speed cannot be controlled. |
| | 4. When the air conditioner is in HEAT mode and enters heating overload prevention operation, the fan speed cannot be controlled. |

NORMAL PHENOMENONS.

When the air conditioner is heating or cooling, plastic components may emit sounds due to temperature changes.



If the indoor humidity is too high, water drops may form on the front grill of the indoor unit. This is a normal phenomenon.

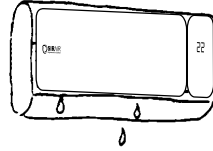

There may be a gentle "rustle" sound when the unit starts or stops. This is the normal sound of flowing refrigerant.



Walls, carpet, furniture, or clothes indoors may emit a peculiar smell.



To protect the unit, there will be a **3-minute** delay before the compressor restarts after stopping.

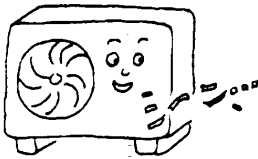

In the first several minutes of heating operation, wind may not come out from the indoor unit.



Water may flow out from the outdoor unit during heating operation.

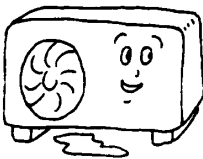

In heating operation, steam may come out when the unit is defrosting.

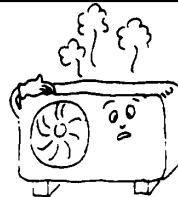

Installation Manual.

Installation Guide:

This air conditioner complies with national safety and operational standards.

It's important to hire professional air conditioning service and maintenance personnel for installations or removals to avoid potential problems or losses due to unprofessional handling.

Ensure that the power supply meets installation and operation requirements.

Refer to the nameplate for details about the voltage required for this product.

Using voltage beyond this scope will affect the normal operation of the air conditioner.

Use a separate power point with a delay fuse protector or automatic breaker for the air conditioner.

Proper grounding of the air conditioner is essential to prevent electric shock or fire hazards.

Do not turn on the power of the air conditioner until the tubing wires are securely connected and carefully checked.

Avoid installing the appliance in the laundry room or bathroom.

If necessary, consult with your supplier or authority for system information.

Ensure that the plug remains accessible after installing the appliance.

Please note that this instruction is subject to change without notice.

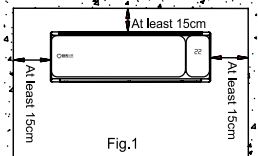

Fig.1

Installation Accessories.

-Carefully examine the attached packing list and verify whether all accessories are included in the package.

-Users may need to purchase, at their own expense, any items not included in the packing list that may be required for installation.

Position for indoor unit.

- Keep the air-conditioner away from heat sources, steam sources, flammable gas leaks, and smoke.

- Ensure there are no obstacles near the inlet and outlet to maintain good ventilation.

- Provide proper drainage for water discharge.

- Maintain a distance of at least **1m** from wireless equipment such as TVs and radios.

- Mount the air-conditioner on a wall capable of bearing its weight and minimizing operational noise.

- The distance between the indoor unit and the floor should be greater than

2.3m.

- Ensure that the plug remains accessible after installing the appliance.

- Follow the distance requirements as shown in **Fig.1.**

- Position the back of the indoor unit close to the wall as illustrated in **Fig.1.**

- Note that all figures provided are schematic and may slightly differ from the actual appliances you receive.

Position for Outdoor Unit.

- Avoid positioning the air conditioner in direct sunlight.
- Place the air conditioner away from heat sources, steam sources, flammable gas leaks, smoke, and dust.
- Choose a location sheltered from rain and snow, with good ventilation.
- Ensure that the airflow, noise, or discharged water from the air conditioner will not disturb neighbors.
- Select a location that is easily accessible for installation and servicing.
- Install the air conditioner on a solid and reliable foundation to minimize noise and vibration.
- For optimal cooling performance, ensure that the unit's front, rear, left, and right sides are located in an open area.
- Keep the outlet of the air conditioner in an open-air space to prevent any obstacles from affecting its performance.
- Follow the installation distance guidelines as shown in **Fig. 2**.

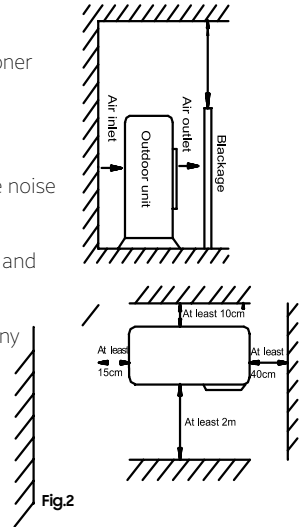

Tubing Selection.

- Ensure that the level (height) difference between the indoor and outdoor units, as well as the length of tubing, meets the requirements outlined in **Table 1**.
- If the tubing length exceeds **7m** but is shorter than **20m**, refrigerant should be supplemented according to **Table 1**.
- If the outdoor unit is installed at a higher position than the indoor unit and the tubing length exceeds **10m**, add an oil trap on the gas tubing for every 8m as shown in **Fig. 3**.

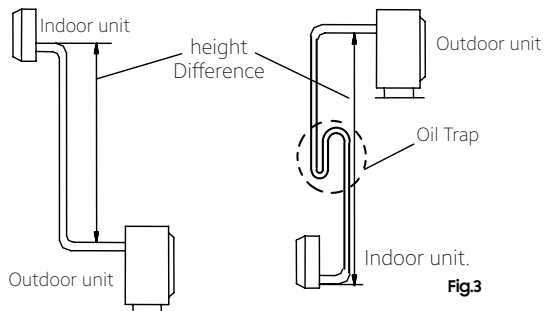

Table 1

| Tubing size(mm/inch) | | Standard Tubing Length (m) | Max Tubing Length (m) | Height Difference (m) | Additional refrigerants (g./m) |
|----------------------|---------------|----------------------------|-----------------------|-----------------------|--------------------------------|
| Liquid Tube | Gas Tube | | | | |
| φ 6(1/4") | φ 9(3/8") | 5.0 | 9 | 5 | 12 |
| φ 6(1/4") | φ 12(1/2") | 5.0 | 12 | 7 | 12 |
| φ 6(1/4") | φ 15.88(5/8") | 5.0 | 15 | 8 | 12 |
| φ 9(3/8") | φ 15.88(5/8") | 5.0 | 15 | 8 | 15 |
| φ 9(3/8") | φ 19.05(3/4") | 5.0 | 20 | 10 | 15 |

The above dimensions are for preference only, the actual product shall prevail.

Fixing Installation Panel.

- Disassemble the metal installation board of the indoor unit and adjust it to a horizontal position. Ensure that the height difference between the left and right sides of the installation board is less than **5mm (refer to Fig. 4)**.
- Drill holes in the appropriate locations on the wall and insert plastic expansion tubes. Secure the installation board to the wall using **M5x30 screws**. Ensure that there are at least 4 fixed points on the wall, and maintain the horizontal position of the installation board throughout **(see Fig. 4)**.
- Drill holes as shown in **Fig. 5**. The hole diameter should be 80mm, allowing slight outward sliding.
- Cut **PVC** tubes at a slight angle to a length shorter than the wall thickness, and insert them into the holes as illustrated in **Fig. 5**.

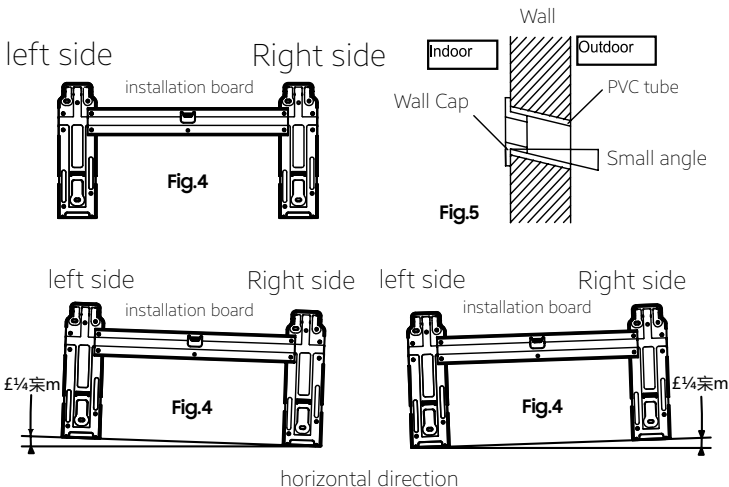

Attachment: Installation Instructions for Decorative Cover Plate.

← outlet drainage  Cover Plate.

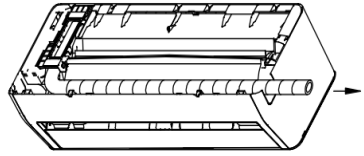
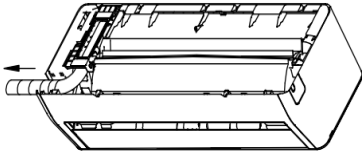

Step 1: Wrap **PVC** protective tape around the drainage pipe, copper pipe, and cable.
Adjust the copper pipe tube to a suitable shape.

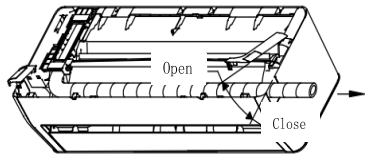
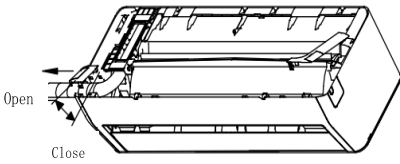

Step 2: Install the cover plate.

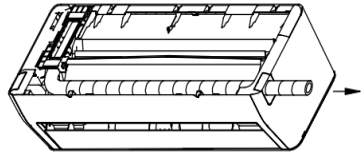
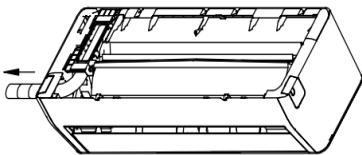

Step 3: Finish

Indoor Unit Installation.

1. Connecting the right back tube **(similar to the right lower tube), (optional)** as shown in **Fig.6**:

- Pull out the tubing from the bottom of the chassis and connect the drainpipe. Ensure to securely strap the joint of the tubing.

- Lead the connecting wire to the indoor unit **(do not connect to the power)**.

- Use adhesive tape to strap together the tubes, discharge pipe, and connecting wire. Place the discharge pipe as indicated below.

- Remove the board from the chassis and verify the connections are reliable.

- Mount the indoor unit on the two hooks at the upper part of the installation board **(refer to Fig.8)**.

2. Connecting the left back tube **(similar to the left lower tube), (optional)** as shown in **Fig.9**:

- Move the discharge tube to the left side and the discharge cap to the right side.

- Secure the tubes in the slot of the indoor unit with the fix clamp.

- Follow the same mounting steps as described in **"1. Connecting right back tube."**

Notes: The left chart is available for the position of the drain hose **(refer to Fig.7)**, while the right chart is available for the position of the drain hose **(refer to Fig.9)**.

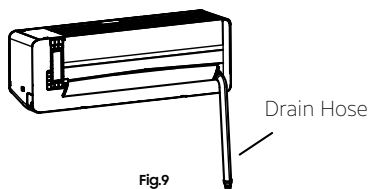
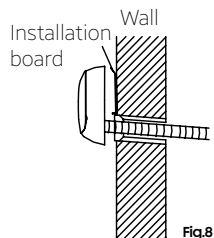
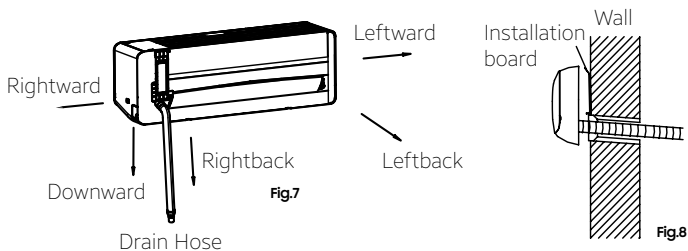
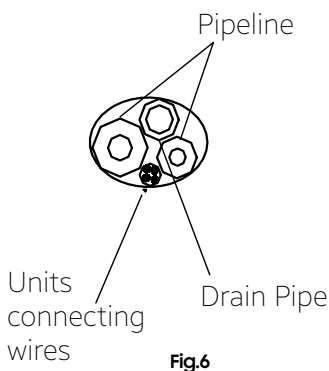

Outdoor Unit Installation.

- If installation brackets for installing the outdoor unit are needed, users can purchase them from our company or agents **(refer to Fig.10)**.

- Assemble the mounting frame and supports using the **6 screws**, plain washers, spring washers, and nuts provided.

- **Drill 6 or more holes** on the wall according to the feet size of the air-conditioner. Determine the locations for mounting the left and right supports, ensuring that they are on the same level.

- Secure the installation frame to the wall using expansive bolts.

- Fix the outdoor unit with **4 bolts** onto the installation brackets.

- Ensure that all fittings are tightly screwed and connections are tight and reliable.

- When installing the outdoor unit, use ropes to hang the body to prevent it from falling.

- During installation or repair, take measures to prevent tools and components from falling.

- Regularly check the reliability of the installation frame.

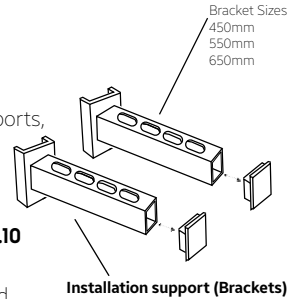

Fig.10

Tubing Connection.

Here are the steps to detach the valve cover of the outdoor unit and connect the tubing properly:

1. Carefully detach the valve cover of the outdoor unit.
2. Align the flaring nut to the thread center, and securely screw the nut by hand.
3. Utilize a torque spanner to tighten the flaring nut until the torque spanner emits a distinct "click" sound.
4. It is highly recommended to use a torque spanner for connecting the tubing. Using other flexible or fixed spanners may result in damaging the horn mouth due to improper force application.
5. Ensure that the bending angle of the tube is not too small, as this may lead to tube breakage. Service personnel should employ a tube bender to bend the tube appropriately.
6. Never permit water, dust, or sand to enter the pipe during installation.

Table 2

| Tubing size (mm/inch) | Torque (N.m) |
|-----------------------|--------------|
| φ 6 (1/4") | 15-20 |
| φ 9(3/8") | 35-40 |
| φ 12(1/2") | 50-55 |
| φ 15.88(5/8") | 60-75 |
| φ 19.05(3/4") | 80-95 |

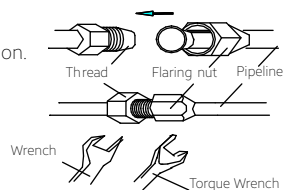

Fig.11

Connection of Wires.

1. Indoor unit.

Here are the steps to connect the power and signal control wires to the unit:

1. Extend the inlet grid to its furthest extent upwards.
2. Remove the electric cover from the unit.
3. Loosen the screw at the connection lid **(refer to Fig.12)**.
4. Disassemble the wire pressure plate.
5. Connect the power connecting wires and signal control wire separately to the corresponding terminals. **(Refer to Fig.14 for the wiring diagram of the unit.)**
6. Loosen the screw on the earth plate and securely attach the earth wire.
7. Firmly press the connecting wires of the unit with the lead wire pressure plate.
8. Close the connection lid, screw it tightly, and close the inlet grid.

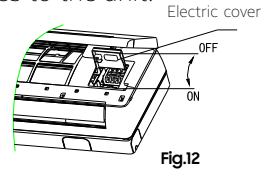

2. Outdoor unit.

Here are the steps to connect the wires of the unit:

1. Loosen and remove the electronic device lid **(refer to Fig.13)**.
2. Disassemble the pressure plate of the wire fastener.
3. Connect the unit's connecting wires separately to the corresponding terminals **(refer to Fig.14)**.
4. Securely press the unit's connecting wires with the top pressure plate.
5. Reattach the electronic device lid to its original position.

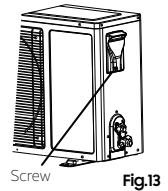

If a user wants to extend or replace the power wire, please follow the instructions provided in the table below **(Table 3)**.

Table 3

| | | Power-connecting wire | Signal-control wire | Powercord |
|-----------------|-----------------------|-------------------------|--------------------------|-------------------------|
| | Max-Length | 10m | 10m | 5m |
| 5K/7K/9K/12K | Cross-sectional area. | $1.0 \text{ mm}^2 \geq$ | 1.0 mm^2 | $\geq 1.0 \text{ mm}^2$ |
| 16K/18K/24K | | $\geq 1.5 \text{ mm}^2$ | $\geq 1.5 \text{ mm}^2$ | $\geq 1.5 \text{ mm}^2$ |
| 18K/21K/24K/28K | | $\geq 2.5 \text{ mm}^2$ | $\geq 0.75 \text{ mm}^2$ | $\geq 2.5 \text{ mm}^2$ |

Connection diagram for 9k,12k,18,24k.

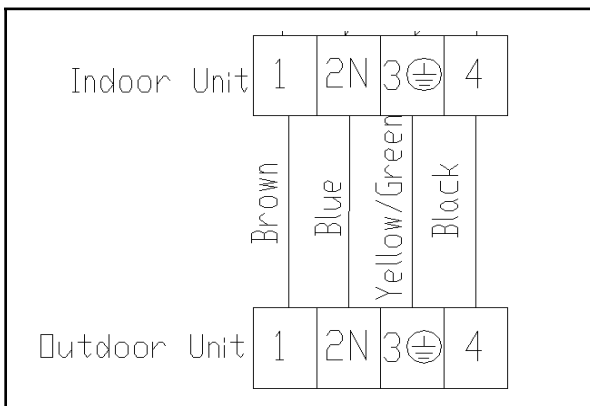

Fig.14

Notes: Here are some guidelines for tube strapping and grounding:

1. Use a special screw for grounding, such as stainless machining screws or copper screws **(M4)**.
2. Ensure all wires are securely connected and will not loosen or separate.
3. Wire connections should follow the wiring diagram of the air-conditioner.
4. Note that the figures provided are schematic and may slightly differ from the actual appliances you select.

For tube strapping:

- When using **PVC** protective tape for strapping, take care not to damage the pipeline and drain pipe.
- Begin strapping from the lower part of the outdoor unit to the indoor unit.
- Secure the **PVC** tape with **adhesive tape** to prevent loosening.
- Ensure the drainpipe slightly slides downward outward to ensure proper drainage.
- If the indoor unit is positioned lower than the outdoor unit, bend the tube appropriately to prevent water from draining into the house.
- Secure the tube bundle with tube clamps on the wall.
- Leave adequate space between the discharge pipe and the ground. Do not place the discharge pipe in water or a ditch.
- Seal the external wall holes with sealing gum or putty.

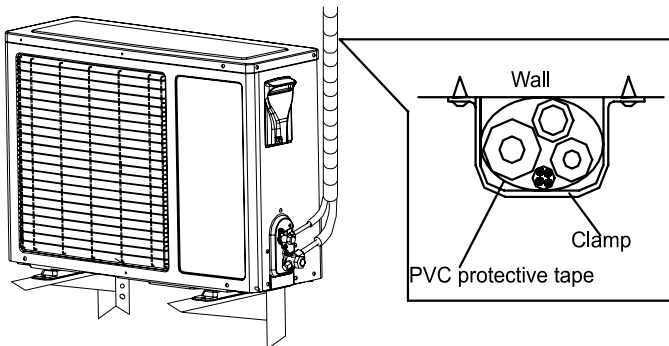

Fig.15

Pumping Type.

Here's a breakdown of the steps for installation:

- Ensure that all tubes of the indoor and outdoor units are properly connected.
- Use a spanner to remove the valve bonnet from two-way and three-way valves, then connect the vacuum pump and compound valve to the service valve bonnet.
- Open the low-pressure switch of the compound valve and run the vacuum pump until the internal pressure of the units reaches **10mm Hg**.
- After achieving the desired vacuum, close the low-pressure switch of the compound valve and then turn off the vacuum pump. Rotate the spool of the narrow pipe service valve anti-clockwise by **90 degrees** using a hexagon spanner, and tighten it clockwise after a **10-second** pause.
- Check all connections of the indoor and outdoor units with soap water or a leak detector to detect any leaks.
- Open the wide and narrow pipe service valves by using a hexagon spanner for operation.
- Remove the connection pipeline of the wide pipe service valve.
- Securely screw the entire valve bonnet using a torque spanner.
- Once again, check all indoor and outdoor connections for leaks using soap water or a leak detector.
- Finally, put the valve bonnet and lid back into position.

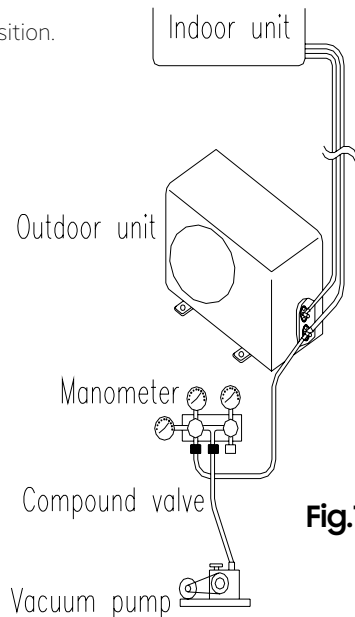

Fig.16

Drainage.

1. No need for drainage treatment.

In regions with cold winters, it's advisable to refrain from installing the drain elbow joint to prevent the freezing of drain water, which could potentially damage the fan. However, this drainage treatment is not required for cooling-only type air-conditioners. Instead.

2. When needing drainage treatment.

Please utilize the drain elbow joint provided in the accessory bag. Furthermore, ensure that the outdoor unit is placed on blocks for proper installation.

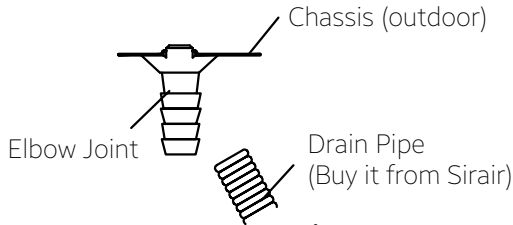

Fig.17

Installation for the cover of Valve:

For units with individual valve covers, follow these steps for installation:

1. After connecting the connection pipes between the indoor and outdoor units as per the installation method mentioned earlier.
2. Retrieve the valve cover from the accessory bag.
3. Securely attach the valve cover to the side of the outdoor unit using the three corresponding screws provided (located inside the accessory bag).

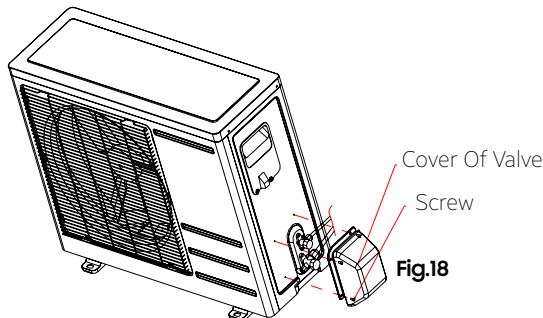

Fig.18



sales@sirair.co.za | 011 315 1246 | www.sirair.co.za
Units 11, 12, 13, 14 Kingston Park | Old Pretoria Main Road
687 Halfway House | Midrand. 1685
